

# Nuclear Magnetic Resonance Spectroscopy. Conformations and Conformational Equilibration of Some Cyclooctane Derivatives<sup>1a,b</sup>

J. Edgar Anderson,<sup>1c</sup> Edward S. Glazer, Dean L. Griffith, Rudolf Knorr, and John D. Roberts

Contribution No. 3721 from the Gates and Crellin Laboratories of Chemistry, California Institute of Technology, Pasadena, California 91109.

Received July 16, 1968

**Abstract:** A study of the temperature dependence of the <sup>19</sup>F nuclear magnetic resonance spectra of 1,1-difluorocyclooctane and 1,1,4,4-tetrafluorocyclooctane has shown that these substances, at low temperatures, prefer to assume the boat-chair conformation. At higher temperatures, pseudorotation within the boat-chair series of conformations becomes rapid and, at still higher temperatures, equilibrations leading to ring inversion become rapid on the nmr time scale. 1,1,2,2-Tetrafluorocyclooctane, at low temperatures, appears to prefer the twist-boat (S<sub>i</sub>) conformation and, at higher temperatures, pseudorotation through the boat-boat conformations becomes rapid. At still higher temperatures, ring inversion becomes rapid on the nmr time scale. At low temperatures, perfluorocyclooctane seems to prefer (i) the twist-boat or (ii) the boat-boat conformation. If i, then even at -173°, pseudorotation through the boat-boat conformation must be rapid. At room temperature, what amounts to ring inversion of perfluorocyclooctane is rapid, apparently by way of equilibration with a conformation(s) outside the boat series. Activation parameters have been obtained for several of these pseudorotation and inversion processes.

While the conformational possibilities for cyclohexane and its derivatives are easily envisaged and there is experimental evidence which allows a choice among these in most cases,<sup>2</sup> the extent of both our present understanding and experimental evidence regarding the conformations of cyclooctane and its derivatives is by contrast meager. A number of calculations have been made of the energies of the more symmetrical possible conformations of cyclooctane itself<sup>3</sup> and methylcyclooctane,<sup>3e</sup> and these suggest that there are certain of these conformations which are particularly stable. Some of these conformations (I to 11) and the energies<sup>4</sup> calculated for each of them by Hendrickson<sup>3d</sup> are shown in Figure 1.

(1) (a) Work supported by the National Science Foundation. (b) Presented in part at the Nineteenth National Organic Chemistry Symposium of the American Chemical Society, Tempe, Ariz., June 17, 1965. (c) Harkness Fellow of the Commonwealth Fund of New York, 1966-1968.

(2) (a) E. L. Eliel, N. L. Allinger, S. L. Angyal, and G. A. Morrison, "Conformational Analysis," Interscience Publishers, New York, N. Y., 1965; (b) M. Hanack, "Conformation Theory," Academic Press, New York, N. Y., 1965.

(3) (a) J. B. Hendrickson, *J. Am. Chem. Soc.*, **83**, 4537 (1961); (b) *ibid.*, **86**, 4854 (1964); (c) K. B. Wiberg, *ibid.*, **87**, 1070 (1965); (d) M. Bixon and S. Lifson, *Tetrahedron*, **23**, 769 (1967); (e) J. B. Hendrickson, *J. Am. Chem. Soc.*, **89**, 7036 (1967); (f) *ibid.*, **89**, 7043 (1967); (g) There has been an unfortunate multiplicity of names to describe the various conformations and it seems desirable to achieve a measure of standardization before computer translation is required to make the papers on cyclooctane conformations intelligible to any but the most intense specialist in the field. While it is true that scientific priority is often assigned on the basis of whose nomenclature for the components of a set of complex ideas is adopted, the present subject is rapidly being made so confused and esoteric by the nomenclature problem that drastic unchaunistic action is needed, now. In view of his extensive work on cyclooctane conformations, with but one exception, we have adopted Hendrickson's notation as standard and we hope others will do the same.

(4) Hendrickson's calculations<sup>3</sup> are of conformational energies,  $\Delta E$ , but, of course, the actual fractional conformational populations depend on the free energies,  $\Delta G$ . The different symmetries of the various conformations could, by entropy contributions, accentuate the differences between the  $\Delta E$  and  $\Delta G$  terms. However, even relatively high symmetry numbers are expected to contribute only a few tenths of a kcal/mol to the free energy terms at the rather low temperatures with which we are concerned here. Throughout the present paper, the

It is to be expected by analogy with cyclohexane that, even if one of these conformations shown in Figure 1 is substantially more stable than the others, cyclooctane molecules will be undergoing conformational equilibration process, such as ring inversion, which will interconvert identical (or enantiomeric) conformations and make each of the hydrogens identical on the average.

The nuclear magnetic resonance (nmr) technique is especially suited to studies of equilibrating conformations<sup>2a,5</sup> although the complexity of the spectra sometimes imposes severe limitations on the kind of information which can be obtained directly. Normally, however, it is possible to simplify complex spectra by replacement of most of the hydrogen atoms in the molecule by deuterium,<sup>6</sup> with or without deuterium decoupling. Another way of achieving the same result, which may provide other advantages, is to use molecules substituted with one or more fluorine atoms, and observe the <sup>19</sup>F spectrum with, or without, decoupling of the adjacent hydrogen atoms.<sup>7</sup> This latter technique has been used in the present research in an effort to shed light on the conformational behavior of cyclooc-

term "energy" will be used for  $\Delta E$  values if we are referring to calculated energies, and  $\Delta G$  values when reference is made to experimentally measured free energies.

It should be noted that Hendrickson<sup>3d</sup> does not consider the parallel-boat conformation 11. This form is of relatively high energy, because, although it loses much of the cross-ring nonbonded repulsions of the boat (2.91 kcal/mol), it retains most of the torsional energy (11.87 kcal/mol). Conformation 11 is related to 8 as follows. The boat form 8 has two sets of four coplanar carbons on the top and bottom of the molecule which define two rectangles. Distortion of 8 to reduce the cross-ring hydrogen-hydrogen interactions and at the same time maintaining the carbon-carbon bonds parallel which are parallel in 8 affords 11 wherein the two sets of four carbons on the top and bottom define two rhomboids.

(5) J. A. Anderson, *Quart. Rev. (London)*, 426 (1965).

(6) Particularly impressive examples are provided by (a) F. A. L. Anet and A. J. R. Bourn, *J. Am. Chem. Soc.*, **89**, 760 (1967), and earlier work quoted therein, and (b) F. A. Bovey, F. P. Hood, III, E. W. Anderson, and R. L. Kornegay, *J. Chem. Phys.*, **41**, 2041 (1964).

(7) J. D. Roberts, *Chem. Brit.*, 529 (1966).

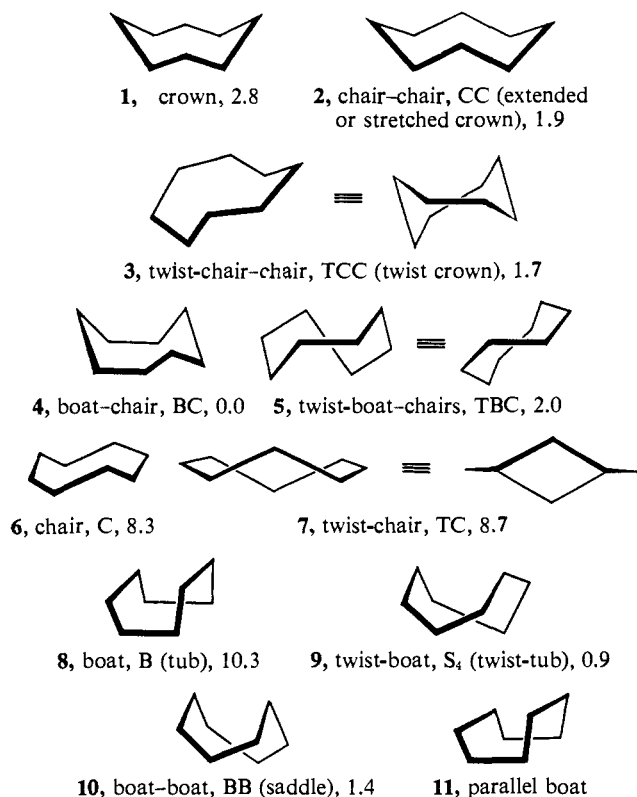

Figure 1. Some of the conformations of cyclooctane. The non-parenthetical names and abbreviations are as given by Hendrickson except for 9 ( $S_4$ ) which is better designated as the twist-boat.<sup>3d</sup> The names in parentheses have been used earlier to some degree or other. The numerical figures are for the calculated energies,<sup>3d</sup> in kilocalories/mole, relative to the boat-chair conformation.

anes, and we report here the results of our examination of the  $^{19}\text{F}$  spectra of some fluorinated cyclooctanes. During the course of this work, Anet and coworkers<sup>8</sup> have made very elegant use of the massive deuteration technique to gain information on the same subject.

Before going into detail about our results, it will be helpful to consider the properties of some of the possible conformations of simple cyclooctanes, and some of the possibilities for inversion and pseudorotation of them. The purpose throughout will be to facilitate deducing the kind of spectrum to be expected for isolated  $\text{CH}_2$  or  $\text{CF}_2$  groups in the ring, the other magnetic nuclei being considered as completely decoupled. It is important to remember that there may be several possible locations for a substituent group on a given conformation, and, therefore, a single *gem*-fluoro group could well lead to a spectrum with several AB quartets, provided that the fluorines are nonequivalent in the various positions and the conformational preferences of the  $\text{CF}_2$  are not so marked as to have some of these positions essentially excluded. If any locations of the  $\text{CF}_2$  are excluded, then fewer AB quartets than the theoretical number of positions will be observed. For this reason, and because all of the chemical shifts may not be separately distinguishable when discussing the various possibilities, we will often use the term "up to  $n$  AB quartets." The situation is much simpler with  $\text{CH}_2$  groups because there will be no preference for

particular locations but, of course, the chemical shifts may easily be too small to distinguish one kind of  $\text{CH}_2$  from another.

In the sequel, it will be very helpful to follow the arguments with the aid of molecular models, preferably of the Dreiding-Fieser type.

### The Crown, Chair-Chair, and Twist-Chair-Chair Conformations

The crown (1), chair-chair (2), and twist-chair-chair (3) conformations are expected to constitute an easily interconverted family of conformations, 2 being obtained from 1 by moving apart any pair of carbon atoms which have a 1,5 relationship to each other. To obtain 3 from 1, it is only necessary to twist relative to one another any two carbon-carbon bonds which are in a 1,5 relationship. Either direction of twist produces 3. These movements are calculated to occur so rapidly and reversibly<sup>3f</sup> that, although 2 and 3 are expected to be of lower energy than 1, molecules in these conformations will appear to have the symmetry properties of 1 even over short periods of observation. All of the carbon atoms of 1 are chemically equivalent, although the substituent atoms carried by any given carbon are not equivalent, being either "axial" or "equatorial" as in 12. Interconversion of 1, 2, and 3 by pseudorotation does not cause ring inversion of the type which leads to interchange of substituents in the axial and equatorial positions. Formation of the inverted form 13 which, like ring inversion of the chair form of cyclo-

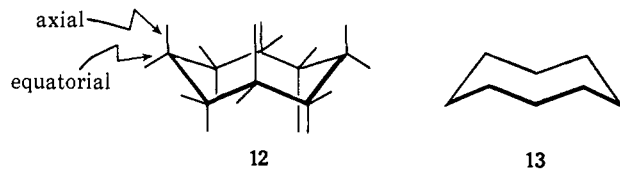

hexane, interchanges axial and equatorial substituents is expected to require intermediate formation of conformations different from 1-3, by processes which would be expected to have relatively high potential barriers. Where these barriers are rapidly surmounted, *gem* substituents on any carbon atom will appear to have identical nmr signals. Pseudorotation between the twist-chair-chair and chair-chair forms does not interconvert axial and equatorial substituents; true inversion of chair-chair forms seems most readily achieved by conversion to, and pseudorotation among, the boat-chair forms.<sup>3f</sup>

If *inversion* of one of these conformations is slow on the time scale of the nmr spectrometer, we would expect to see an AB quartet for *gem*-hydrogens or -fluorines on any given carbon atom. If interconversion of the forms 1-3 by pseudorotation is also slow, then depending on which of these forms is more stable we would expect to see, for the crown (1) a single AB quartet; for the chair-chair, up to three AB quartets, corresponding to the three kinds of carbon atoms in 2; and for the twist-chair-chair (3), up to two AB quartets.

### The Boat-Chair Family of Conformations

There are five nonequivalent carbons in the boat-chair conformation; see 14. A pseudorotation is possible in which carbon 2 in 15 moves over one posi-

(8) (a) F. A. L. Anet and J. S. Hartman, *J. Am. Chem. Soc.*, **85**, 1204 (1963); (b) F. A. L. Anet and M. St. Jacques, *ibid.*, **88**, 2585 (1966); (c) *ibid.*, **88**, 2586 (1966); M. St. Jacques, M. A. Brown, and F. A. L. Anet, *Tetrahedron Letters*, 5947 (1966).

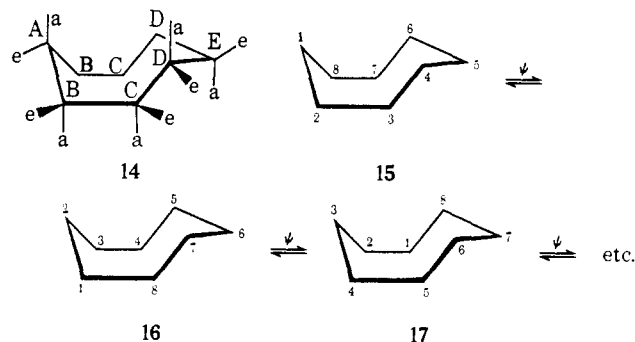

tion as shown to give **16**.<sup>9</sup> An intermediate in this pseudorotation process is the twist-boat-chair **5** which will be discussed below. A similar pseudorotation of **16** with C-8 moving toward C-3 gives **15** back again. If the pseudorotation of **16** begins with C-5 moving toward C-1 then **17** results. The complete sequence of pseudorotations causes each carbon to move through all of the positions A, B, C, D, and E of **14** so that the carbons on the average are equivalent. However, if axial and equatorial substituent positions are defined as shown in **14** at A, B, C, D, and E, the full cycle of pseudorotations does not allow an axial substituent to occupy an equatorial substituent position on the *same* atom. Thus, an axial substituent in the A position (A,a) passes through the following cycle.

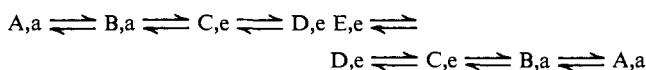

As a result, while pseudorotation averages the carbon positions it does not average the substituent positions. For complete averaging of the substituent positions, some other process is required.<sup>3f</sup> This could be a movement apart of carbons 3 and 7 in **13** through the twist-chair conformation **19** (in which it will be noted, the *gem* substituents at positions 3 and 7 are identical) to a new boat-chair **20**. An A,a substituent in **18** becomes E,a in **20**, a position which it could not reach by pseudorotation. Another reasonable possibility for averaging substituent positions is to have, at the twist-boat-chair stage of the pseudorotation cycle (for example, **22**, wherein the twofold axis passes through the midpoints of the C-1 to C-2 and C-5 to C-6 bonds), movement of C-5 toward C-2 and subsequent downward flip of C-4 which leads to the chair form **23**. In **23**,

(9) The pseudorotation which interconverts **15** and **16** is a fairly subtle process (see Hendrickson<sup>3f</sup> for an alternative but less detailed discussion) and not one which is easily reproduced with a model. A convenient procedure for observing how this transformation can occur is to employ a Dreiding-Fieser model and to set it up exactly as in **15**, being sure that the 3,4 and 7,6 bonds go upward to the right rather than downward. In the first step, one moves the equatorial bond on C-8 and the axial bond on C-4 toward one another until the equatorial bond on C-8 has just passed by what was the axial bond at C-1, and the inward-directed bond on C-4 is pointed midway between the inward-directed bonds on C-1 and C-8. If this has been done correctly, the inward-directed bond on C-7 points midway between substituent bonds on C-2 and C-3 on the opposite side of the molecule and there is a twofold symmetry axis passing through the midpoints of the C-1 to C-2 and the C-5 and C-6 carbon-carbon bonds. At this point, the model represents the twist-boat-chair form **5**. Now slightly twist (in opposite directions) C-2 and C-6 to bring the bonds attached to them into the same plane, with the bond to become equatorial at C-6 in **16** approximately parallel to the bond at C-2 which is axial. In this process, the substituent at C-8 continues to pass the substituent at C-1 in **16**. The model has finally to be turned over in order to come out in the same orientation as shown in **16**.

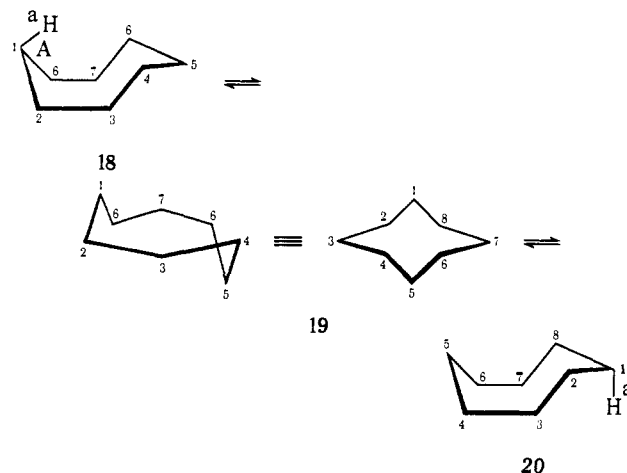

carbons 1 and 5 are identical, so that a boat-chair form can be regenerated by carbon 8 flipping down and carbon 1 moving away from carbon 6 (instead of 4 flipping up and 5 away from 2) to lead eventually to **24**. An A,a substituent in **21** becomes an E,a substituent in **24**, a position which it could not reach by pseudoro-

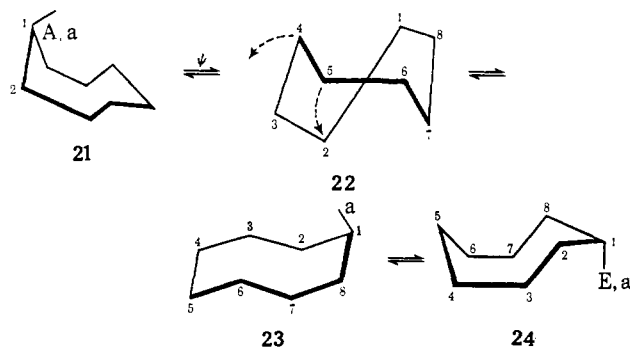

tation alone. Thus, a combination of pseudorotation and one of the inversion processes averages all of the substituent positions (see also Hendrickson<sup>3f</sup>). This series of pseudorotations and inversions forms a closed cycle for the boat-chair (**4**) and for the twist-boat-chair (**5**), and if it were to turn out that the twist-boat-chair is more stable than the boat-chair (opposite to Figure 1, where the calculated relative energies are the reverse by 2 kcal/mol), the sequence for conformational equilibration is the same, with only the identity of the points of lowest energy in each cycle being different. In either case, slowing of inversion should lead to one AB quartet. Slowing of pseudorotation should give up to five AB quartets for the boat-chair and up to four AB quartets for the twist-boat-chair.

### The Boat Series. The Twist-Boat Conformation

In the twist-boat conformation there are only two kinds of carbons. This may not be very evident from **9** which is drawn to represent the intermediacy of the twist-boat form between the boat and the boat-boat, but is readily apparent from models. These carbon atoms are designated here as either inner (i) marked with an asterisk in **25** or outer (o). The two substituents

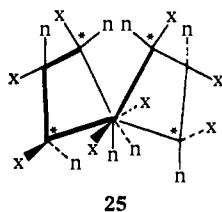

borne by each atom are appropriately named *endo* (n) and *exo* (x); see 25. The twist-boat form is expected to be able to pass through an integral sequence of pseudorotations involving boat and boat-boat forms. Part of this sequence is shown below 27 → 28. In going from 26 to 27 through the boat-boat, the outer

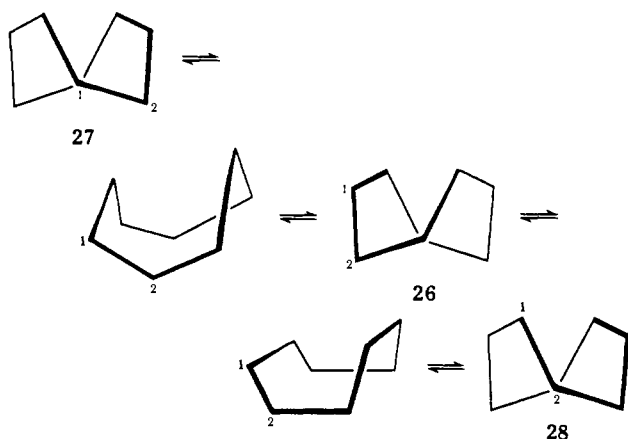

and inner carbon atoms remain as they are, but the substituents change as shown below, where o,n denotes an *endo* substituent on an outer carbon. In going from

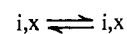
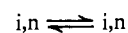
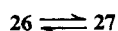

26 to 28 through the boat, the outer carbon atoms become inner and *vice versa*. *exo* and *endo* substituents stay *exo* and *endo*, respectively. This is summarized below.

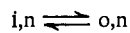
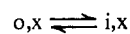
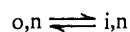
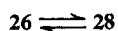

Thus, passage through a boat renders all of the carbons identical, but the distinction between *endo* and *exo* substituents remains. Passage through the boat-boat does not make the carbons equivalent, but does remove the distinction between *exo* and *endo* for a substituent on an outer carbon atom. Successive passages through boat and boat-boat conformations will completely average the substituent positions.

We have discussed above only some of the more obvious conformational equilibration processes avail-

able to the cyclooctane system, but these processes are the ones which are more germane to the interpretation (or rationalization as depends on one's point of view) of the experimental data obtained in the present research.

Before publication of recent nmr and X-ray crystallographic studies, the weight of evidence, though in no way conclusive, was in favor of the crown or boat-boat conformations for cyclooctanes.<sup>10</sup> However, three recent X-ray studies of *cis*-1,2-cyclooctanedicarboxylic acids<sup>11a</sup> and *trans*-1,2-cyclooctanedicarboxylic acids<sup>11b</sup> and dimeric cyclooctanone peroxide<sup>11c</sup> indicate that the preferred conformation of these compounds in the crystalline state is the boat-chair. Also Anet's work<sup>3</sup> on deuterated cyclooctanes and substituted cyclooctanes shows convincingly that for these substances the preferred conformation is the boat-chair, and has furthermore permitted measurement of the barrier to inversion of these conformations.

The calculations of relative energies of conformations<sup>3</sup> of cyclooctane (see Figure 1) indicate that several quite different forms have rather similar energies and for this reason caution should be exercised in drawing conclusions about more complex eight-membered rings on the basis of results for simple cases. Examples are provided by X-ray crystallographic studies of 29<sup>12a</sup> and *trans-syn-trans*-1,2,5,6-tetrabromocyclooctane<sup>12b</sup>

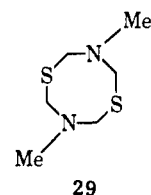

for which the crown and twist-crown conformations, respectively, have been found to be correct.

We shall now discuss temperature dependence of the <sup>19</sup>F nmr (fmr) spectra of 1,1-difluorocyclooctane, 1,1,4,4-tetrafluorocyclooctane, 1,1,2,2-tetrafluorocyclooctane, and perfluorocyclooctane which appear to give qualitative and quantitative information on inversion and pseudorotation of several of the cyclooctane conformations outlined above.

### Experimental Results

At ambient temperature, the fmr spectrum of 1,1-difluorocyclooctane is a quintet 89.0 ppm upfield from fluorotrichloromethane, in propene as solvent, with  $J_{HF} = 15.1$  Hz. Under double irradiation at the proton resonance frequency, a single sharp signal is observed. This sharp line broadens and splits into a closely packed AB spectrum below  $-100^\circ$ . The rates of exchange as a function of temperature were determined by comparison of theoretical spectra calculated as a function of  $\tau$ , the mean lifetime before exchange,

(10) A recent summary is given by J. Dale, *Angew. Chem.*, **78**, 1070 (1966); *Angew. Chem. Intern. Ed. Engl.*, **5**, 1000 (1966).

(11) (a) J. D. Dunitz and A. Mugnoli, *Chem. Commun.*, 166 (1966). This paper also reinterprets earlier results that favored assignment of the crown conformation; see J. D. Dunitz and V. Prelog, *Angew. Chem.*, **72**, 896 (1960). (b) J. D. Dunitz, as quoted by Hendrickson,<sup>3d</sup> (c) P. Groth, *Acta Chem. Scand.*, **19**, 1497 (1965).

(12) (a) F. G. Riddell and G. Weiss, private communication; see also F. G. Riddell and J. M. Lehn, *Chem. Commun.*, 803 (1966); (b) G. Ferguson, D. D. MacNicol, W. Oberhansli, R. A. Raphael, and J. A. Zabkiewicz, *ibid.*, 103 (1968).

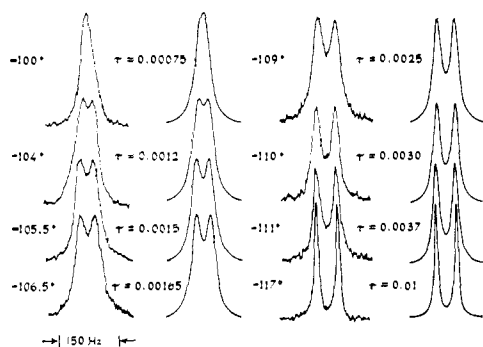

Figure 2. Experimental and calculated fluorine nmr spectra for 1,1-difluorocyclooctane in propene. Only the inner quartet lines are shown.

in the usual way<sup>7,13</sup> between  $-100$  and  $-121^\circ$  (see Figure 2). Below  $-121^\circ$  the chemical-shift difference of the AB quartet was found to remain constant at 165 Hz (3.92 ppm) with  $J_{AB} = 245$  Hz. The free energy of activation ( $\Delta G^\ddagger$ ) for the exchange process is approximately 7.5 kcal/mol at  $-100^\circ$ , the average entropy of activation is 6 eu, and  $E_a$ , the Arrhenius activation energy, is 8.4 kcal/mol.

Below  $-150^\circ$ , the closely packed AB spectrum broadens and subsequently splits into two superimposed AB quartets as shown in Figure 3. The predominant quartet (63%) has a rather smaller fluorine-fluorine chemical-shift difference,  $\delta_{FF}$  (806 Hz), and geminal fluorine-fluorine coupling,  $J_{FF}$  (240 Hz), than the minor quartet (37%) which has a  $\delta_{FF}$  of 940 Hz and  $J_{FF}$  of 245 Hz. The difference in free energy of the two conformations represented by these signals is 0.11 kcal/mol at  $-175^\circ$ . The spectral lines of each quartet come as shown diagrammatically in Figure 4 where  $a_1$  and  $a_2$  denote the upfield resonances which are superimposed (see Figure 3), and  $b_1$  and  $b_2$  denote the downfield resonances. Exchange averaging of these resonances at intermediate temperatures (above  $-150^\circ$  and below  $-121^\circ$ ) can occur in three ways. (1) The nuclei with shift  $a_1$  can exchange places with  $b_1$  and  $a_2$  with  $b_2$ . With rapid exchange, this would produce two *single* lines with relative intensities 63:37 and separated by about 70 Hz. (2) Also possible would be exchange of the nuclei with shift  $a_1$  with those of shift  $a_2$  and  $b_1$  with  $b_2$ . This would produce an AB spectrum with a chemical shift of about 850 Hz. (3) Finally, the shifts which are averaged could be  $a_1$  with  $b_2$  and  $a_2$  with  $b_1$ . Such averaging would afford the observed  $-120^\circ$  spectrum, a closely packed AB quartet, with a chemical shift difference of about 160 Hz.

Spectra calculated as a function of  $\tau$  for the  $a_1 \rightleftharpoons b_2$  and  $a_2 \rightleftharpoons b_1$  exchanges<sup>18c</sup> could be fitted to the experimental spectra between  $-160$  and  $-170^\circ$  as shown in Figure 3. The free energy of activation ( $\Delta G^\ddagger$ ) for exchange was found to be 4.9 kcal/mol at  $-160^\circ$ , the average entropy of activation 28 eu, and  $E_a = 8.0$  kcal/mol.

At ambient temperatures, the fmr spectrum of 1,1,4,4-tetrafluorocyclooctane in propene is a quintet cen-

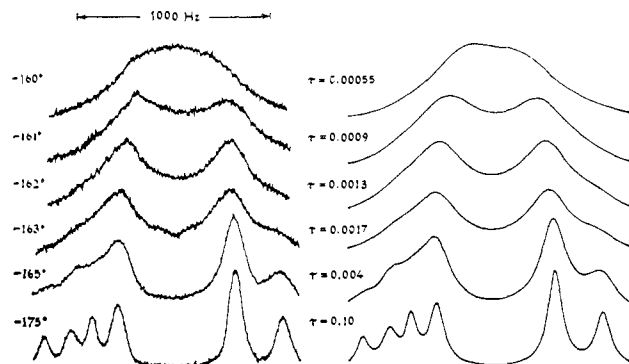

Figure 3. Experimental and calculated fluorine nmr spectra for 1,1-difluorocyclooctane in propene.

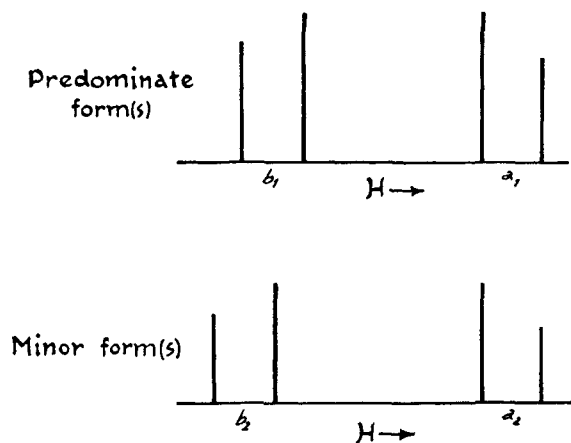

Figure 4. Schematic representation of fluorine signals for two different forms (or groups of forms) of 1,1-difluorocyclooctane.

tered 80 ppm upfield from external fluorotrichloromethane, with  $J_{HF} = 13.7$  Hz. Under double irradiation at the hydrogen frequency, a single sharp line is observed. When cooled to below about  $-80^\circ$ , the single sharp line broadens and becomes what may be a closely packed AB spectrum.

When the temperature is reduced to below  $-124^\circ$ , the broad line splits into two equally intense AB spectra with equal F-F couplings (253 Hz) but different line widths and chemical-shift differences (920 and 837 Hz, respectively) as can be seen from Figure 5. The same procedure used for 1,1-difluorocyclooctane was employed to find the correct sets of exchanging AB nuclei and it is predicted that the broad line at  $-85^\circ$  should be an AB quartet, with the inner lines strong and separated by about 10 Hz and the outer lines very weak. Theoretical spectra calculated as a function of  $\tau$  could be fitted to the experimental spectra as a function of temperature between  $-124$  and  $-137^\circ$ . The free energy of activation for the exchange obtained from these data is 6.1 kcal/mol at  $-130^\circ$ , the average entropy of activation is 23 eu, and  $E_a$  is 9.4 kcal/mol.

The fluorine spectrum of 1,1,2,2-tetrafluorocyclooctane in propene solution at ambient temperatures is a broad multiplet 110 ppm upfield from external fluorotrichloromethane. The multiplet collapses to a single sharp line on irradiation at the proton resonance fre-

(13) (a) S. Alexander, *J. Chem. Phys.*, **37**, 967, 974 (1962); **38**, 1787 (1963); **40**, 2741 (1964); (b) J. L. Beauchamp, Undergraduate Thesis, California Institute of Technology, Pasadena, Calif., 1964; (c) J. T. Gerig and J. D. Roberts, *J. Am. Chem. Soc.*, **88**, 2791 (1966).

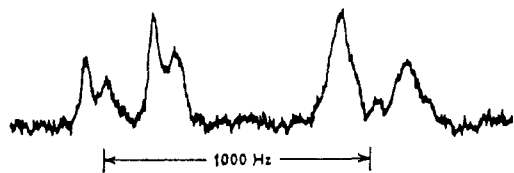

Figure 5. Fluorine NMR spectrum of 1,1,4,4-tetrafluorocyclooctane in propene at  $-160^{\circ}$ .

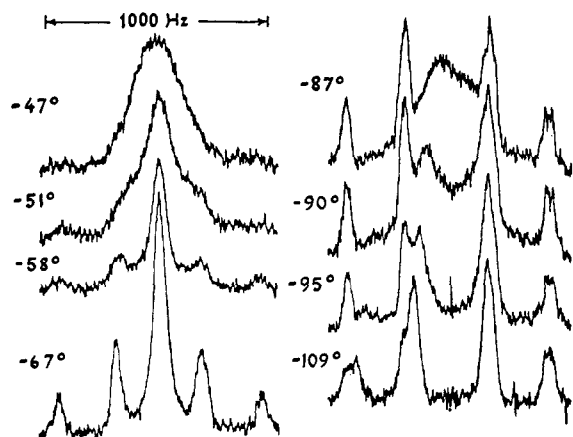

Figure 6. Fluorine spectra of 1,1,2,2-tetrafluorocyclooctane in propene as a function of temperature.

quency. When the sample is cooled, the line broadens and, at  $-49^{\circ}$ , it splits to form an AB quartet which at  $-65^{\circ}$  has a relative chemical shift of 587 Hz ( $J_{AB} = 261$  Hz) superimposed on a rather broad singlet which could conceivably be an AB quartet with a small chemical-shift difference (Figure 6). The singlet line is not quite centered in the large AB quartet and integration of the peak areas suggests that the quartet and the singlet have the same total intensities.

Below  $-81^{\circ}$ , the central singlet peak broadens and then splits into an AB pattern with a large chemical-shift difference such as to almost coincide with the other AB quartet which remains unchanged below this temperature. Spectra calculated assuming equilibrations involving boat conformations to be favored for this compound (see below) could be fitted to the experimental spectra in both temperature ranges of spectral change. On this basis, the high-temperature process has a  $\Delta G^{\ddagger}$  of 10.3 kcal/mol at  $-60^{\circ}$  and the low-temperature process has a  $\Delta G^{\ddagger}$  which is 7.7 kcal/mol at  $-96^{\circ}$ .

At ambient temperatures, perfluorocyclooctane<sup>14</sup> in 2:1 dimethyl ether-dichlorodifluoromethane gives a single sharp resonance line, 2.1 Hz wide at half-maximum height, coming 112.6 ppm upfield from dichlorodifluoromethane. Below about  $-20^{\circ}$ , the line begins to broaden and splits into two broad peaks below  $-51^{\circ}$  (see Figure 7). On further cooling to below  $-65^{\circ}$ , the

(14) We are grateful to Dr. L. F. Thomas, University of Birmingham, for a sample of this substance the fluorine spectrum of which he has investigated to  $-70^{\circ}$  at 94.06 MHz: A. Peake, J. A. Wyer, and L. F. Thomas, *Chem. Commun.*, 95 (1966). The present experimental results are in substantial agreement with those reported to  $-70^{\circ}$  but the interpretation in terms of specific conformations and conformational equilibration is different.

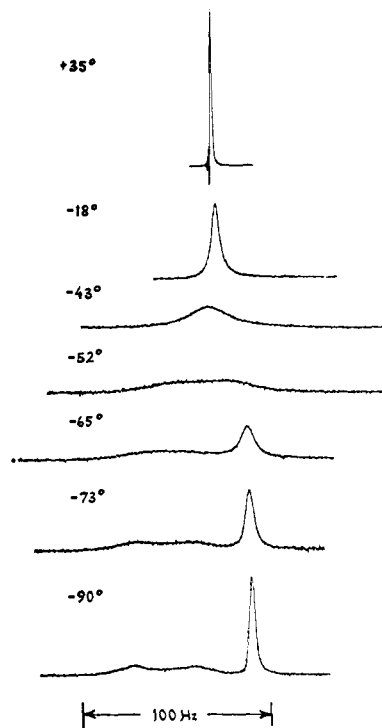

Figure 7. Partial fluorine spectrum of perfluorocyclooctane in 2:1 dimethyl ether-dichlorodifluoromethane as a function of temperature. The broad doublet is the center of an AB quartet, the weak outer lines of which can be observed by time averaging (see text).

downfield peak itself then splits into a doublet. No other evidence for exchange processes has been found below  $-85^{\circ}$ ; the breadth of the downfield resonances at  $-90^{\circ}$  and below may well be the result of cross-ring fluorine-fluorine couplings. Observation of such couplings should be particularly favorable with conformations of perfluorocyclooctane having transannular fluorines close together in space (e.g., **8**, **9**, and **10**).

Thomas<sup>14</sup> has suggested that the downfield doublet observed below  $-65^{\circ}$  is comprised of the inner lines of an AB quartet with  $J_{AB} = 297$  Hz, and enhancement of the spectra with a computer of averaged transients has enabled us to confirm this, the outer peaks of the quartet appearing about  $310 \pm 10$  Hz from the inner members. On cooling the sample to  $-173^{\circ}$ , no further spectral changes were observed other than general broadening which could be attributed to increased viscosity and magnetic field inhomogeneity. It was not found possible to satisfactorily calculate theoretical spectra as a function of  $\tau$  to match those obtained experimentally (see Experimental Section). However, for the temperature range and chemical shifts involved, it is estimated that  $\Delta G^{\ddagger}$  of exchange is of the order of 11 kcal/mol.

## Discussion

If we consider only the equilibrations discussed in the introductory section, the changes in NMR spectrum expected with decreasing temperature for a cyclooctane with an isolated  $\text{CH}_2$  (or  $\text{CF}_2$ ) group in the conformations calculated to be of low energy by Hendrickson<sup>3d</sup> are summarized below.

**1. The Chair-Chair Series.** At intermediate temperatures, inversion but not pseudorotation should be

frozen out; therefore one AB quartet is expected. At low temperatures, pseudorotation should be frozen out and there should be one AB quartet for the crown, or up to three for the chair-chair, or up to two for the twist-chair-chair.

**2. The Boat-Chair Series.** At intermediate temperatures, one AB quartet is expected, while at low temperatures, up to five AB quartets should be observed for the boat-chair and up to four for the twist-chair-chair.

**3. The Boat Series.** At intermediate temperatures, for a twist-boat conformation which passes rapidly through a boat-boat conformation, the spectrum is expected to be the same as for the boat-boat conformation. In either case there would be two kinds of carbon atoms, and *gem* substituents on one of these will be inner and outer which will lead to an AB quartet. The other kind of carbon, as the result of  $C_2$  symmetry, has identical environments for *gem* substituents and these would give a single resonance line. At low temperatures the twist-boat conformation is expected to give up to two AB quartets, while the boat-boat conformation would be unchanged from that at intermediate temperatures.<sup>15</sup>

In light of these possibilities, the results for 1,1-difluorocyclooctane and for 1,1,4,4-tetrafluorocyclooctane are incompatible with either the twist-boat or boat-boat conformations alone, because, at intermediate temperatures, only one AB quartet is actually observed. The intermediate temperature spectrum of 1,1-difluorocyclooctane can be reconciled with a twist-boat or boat-boat conformation by postulating that the geminal difluoro group resides exclusively on inner carbons. However, if this were the case, it seems incredible that, at very low temperatures, four kinds of substituents would be observed as might arise from a change to a substantial population with  $CF_2$  groups at the outer carbons. Furthermore, for the 1,1,4,4-tetrafluoro compound, if the conformation were a twist-boat or a boat-boat, and carbon atom 1 were inner, then carbon atom 4 is automatically outer, and three kinds of substituents should be observed at intermediate temperatures. This is not the case.

The results for the 1,1-difluoro- and 1,1,4,4-tetrafluorocyclooctanes are consistent with either the chair-chair series or the boat-chair series of conformations. For either, we would expect an AB quartet at intermediate temperatures and several AB quartets at low temperatures. For both compounds, only two AB quartets are observed at low temperature, with the relative weights 63:37 for the difluoro compound and 50:50 for the tetrafluoro compound. These results serve to completely exclude the true crown conformation as the favored low-temperature form because it would give a single AB quartet.

To make further progress we need to choose one of

(15) Alternatively, the twist-boat conformations might be interconverted through the boat conformation and, if so, would give an AB quartet at intermediate temperatures and two AB quartets at low temperatures. This mode of interconversion does, in fact, account nicely for some of the experimental results on fluorine-substituted cyclooctanes to be discussed later<sup>1b</sup> but suffers from two serious difficulties. First, it is not at all consistent with the data obtained by St. Jacques and Anet<sup>9</sup> for massively deuterated cyclooctanes and, second, it seems wholly out of line with Hendrickson's calculations,<sup>3d</sup> which indicate that interconversion of twist-boat conformations should occur much more readily through the boat-boat than through boat conformations.

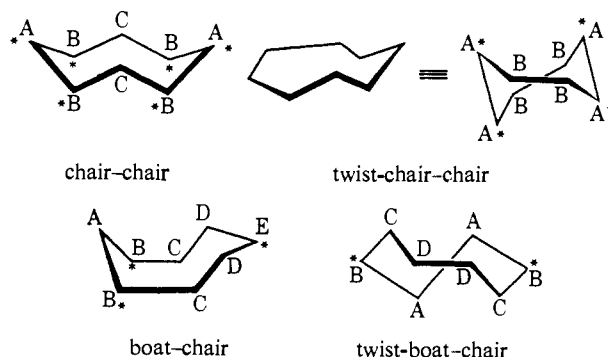

Figure 8. Conformations of cyclooctane of the chair-chair and boat-chair series predicted by Hendrickson to be of lowest energy with most favorable carbons for location of *gem*-fluorines marked with asterisks. In each conformation, those carbons equivalent by symmetry are marked with the same letters.

two alternative approaches. One possibility is that the two AB quartets observed at low temperatures derive from *different kinds* of conformations which are equilibrated rapidly enough by pseudorotation at intermediate temperatures to give a single AB quartet. Thus, for the 1,1-difluoro compound, we might have, for example, 63% boat-chair, and 37% twist-boat-chair, provided we assume that there is but one position in each of these conformations which a  $CF_2$  group prefers to occupy for steric reasons. However, it seems more likely that energy differences between different conformations (*e.g.*, the boat-chair and twist-boat-chair) are larger than the energy differences between the same conformation with the substituent groups in different positions. This seems an especially significant consideration for 1,1,4,4-tetrafluorocyclooctane, wherein with this approach the *different* conformations would have to have negligible energy differences but substituent effects on the *same* conformation would have to be large.

For this reason, we prefer a second approach, namely that the same basic conformations with different substituent locations give rise to the multiple AB quartets and the difference in populations observed with the 1,1-difluoro and 1,1,4,4-tetrafluoro compounds arises from the symmetry properties of the favored low-temperature conformation.

The energy differences to be expected between forms derived from a given basic conformation with the fluorines at different locations, for the chair-chair, twist-chair-chair, boat-chair, and twist-boat-chair conformations, may be deduced qualitatively by inspection of models, on the basis of the magnitudes of transannular interactions. The favorable positions so selected agree with Hendrickson's calculations of the energies of the same conformations with methyl substituent at the various positions.<sup>3e</sup> The favorable locations for *gem*-fluorines are marked with asterisks in Figure 8. Not all of the carbons marked with asterisks in Figure 8 are equivalent and capital-letter designations are used to denote those carbons which are equivalent by symmetry.

The low-temperature spectra shown in Figure 3 demonstrate that 1,1-difluorocyclooctane exists in at least two isomeric forms, presumably of the same conformation, and present in somewhat different amounts. If we accept the existence of preferred positions on the

basis of the results with the 1,1-difluoro compound and then consider 1,1,4,4-tetrafluorocyclooctane, we are provided with evidence against the twist-chair-chair and the twist-boat-chair conformations at the lowest temperatures. The reason is that in these forms there is one kind of preferred position which occurs in a 1,4 relationship, so that for 1,1,4,4-tetrafluorocyclooctane there should be a sharply enhanced preference for one or the other of the forms which gives rise to one of the AB quartets for 1,1-difluorocyclooctane. The result should be a prominent AB quartet with perhaps a small contribution of a different AB quartet corresponding to the second (or other) conformation of 1,1-difluorocyclooctane. Certainly we would not expect two equally prominent AB quartets.

In the boat-chair and chair-chair conformations, there are two different kinds of preferred positions, and these are again in a 1,4 relationship. The two preferred positions will now be of slightly different energies, so that for 1,1-difluorocyclooctane, in either a boat-chair or a chair-chair conformation, we would expect to see two AB quartets in unequal amounts at low temperatures. For 1,1,4,4-tetrafluorocyclooctane, there is one chair-chair conformation, **30**, and one boat-chair conformation, **31**, wherein each CF<sub>2</sub> group occupies a preferred position, but the two preferred positions involve nonequivalent carbons. Other possible arrangements such as having the *gem*-fluorine pairs at A and A or B and B are ruled out as not having the appropriate 1,4 relationship. The proposed favorable

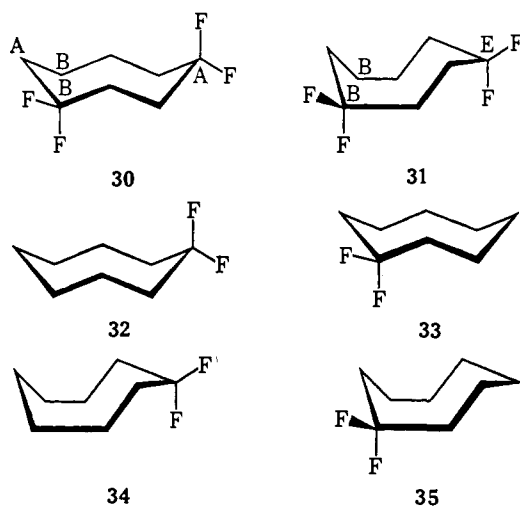

arrangements are expected to lead to the observed two equally intense AB quartets at low temperatures. If the difluoro and tetrafluoro compounds have similar conformational preferences then we can conclude that 1,1-difluorocyclooctane exists as a 63:37 mixture of either **32** and **33** or of **34** and **35** and that 1,1,4,4-tetrafluorocyclooctane exists essentially exclusively as either **30** or **31**, respectively. At the intermediate temperatures, we assume that pseudorotation averages the shifts of the substituents at A,a and B,a in **30** or B,a and E,e in **31**.

In a chair-chair as well as in a boat-chair conformation, the chemical shifts of the axial substituents at the two favored positions should be rather similar, as should also be the chemical shifts of the equatorial

substituents. This is indeed observed but does not allow a decision between the two conformations. However, pseudorotation at intermediate temperatures leads to different predictions for the two models. In the chair family, rapid pseudorotation averages the two equatorial positions with each other, and likewise the two axial positions, so that the two AB quartets should average to one AB quartet, but still with a large relative chemical shift. The boat-chair pseudorotations<sup>9</sup> interchange axial and equatorial at B and E (in **31**) and *vice versa*, and should give rise to a closely packed AB quartet, which is in fact observed.

Thus, the boat-chair model correctly predicts the collapse of the two AB quartets both for 1,1-di- and 1,1,4,4-tetrafluorocyclooctane and is furthermore in accord with the experimental<sup>8</sup> and theoretical<sup>1d</sup> results which show the boat-chair to be the most stable conformation for cyclooctane itself.

In view of the above discussion, it should be clear that the intermediate temperature spectra of neither 1,1,2,2-tetrafluorocyclooctane nor perfluorocyclooctane can be explained by pseudorotations among chair-chair or boat-chair conformations because three kinds of substituent resonances are observed. The spectra of these substances can, however, be explained within the boat series of conformations. Thus, the spectrum of 1,1,2,2-tetrafluorocyclooctane at the low-temperature limit is as expected for the twist-boat conformation with all pseudorotation stopped. The fact that there is only a high-temperature exchange process for perfluorocyclooctane can be interpreted to mean that for this molecule, either pseudorotation between twist-boat conformations *via* a boat-boat conformation is much more facile than with 1,1,2,2-tetrafluorocyclooctane and cannot be slowed enough for observation by nmr, even at  $-173^\circ$ , or (and perhaps better) that the molecule prefers the true boat-boat conformation.

It will be recalled that, in the intermediate-temperature spectrum of 1,1,2,2-tetrafluorocyclooctane, there is a resonance described as a singlet which could conceivably be an AB quartet with a small chemical-shift difference. If, at the intermediate temperatures, passage through the boat form is slow, but passage through one boat-boat conformation is still fast, then the two allowed twist-boat conformations are **36** and **37**. It will be noted that the two outer fluorines exchange between *exo* and *endo* positions in the **36**  $\rightleftharpoons$  **37** equilibrium.

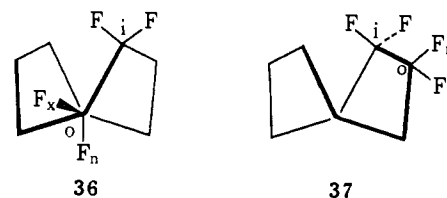

However, in **37** the outer and inner carbon atoms are on the same (the top) side of the molecule while in **36** they are on opposite sides. Thus **36** and **37** should have at least slightly different energies, and the o,x and o,n positions in **36** are slightly different from the o,x and o,n positions in **37**. Thus, although the o,x and o,n positions equilibrate, the resulting resonances for the *gem*-fluorines on an outer carbon atom should nonetheless be an AB quartet, although very plausibly with a small chemical-shift difference. In perfluoro-



cyclooctane, there is greater symmetry and the *gem*-fluorines on the outer carbons give rise to a singlet which is very narrow compared with the singlet of 1,1,2,2-tetrafluorocyclooctane, as can be seen by comparison of Figures 6 and 7.

We may well ask at this point what justification there is for expecting a change in basic conformation between, on the one hand, cyclooctane, 1,1-difluorocyclooctane, and 1,1,4,4-difluorocyclooctane and, on the other, 1,1,2,2-tetrafluorocyclooctane and perfluorocyclooctane. First, and very important, is the fact that the twist-boat and boat-chair conformations are predicted<sup>16</sup> to have very similar energies and, as a result, relatively small factors might be able to achieve a marked change in the type of conformation favored. Second, the patterns of spectral behavior are quite definitely different, and the spectral changes occur at quite different temperatures. Third, there could be differences in dipole interactions between vicinal CF<sub>2</sub> groups for the various conformations which could be greater than the differences in energy of the cyclooctane conformations themselves. Thus, two CF<sub>2</sub> groups, contiguous and staggered as shown in 37, can be calculated to have a dipolar interaction energy of 2.99

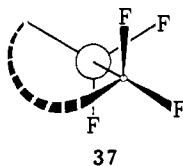

kcal/mol.<sup>17</sup> The corresponding eclipsed form would have an interaction energy of 4.13 kcal/mol so that there will be expected to be sizable differences in the dipolar factor alone between conformations in which the degree of eclipsing of the vicinal fluorines is not the same.<sup>18</sup> It appears in general that the twist-boat and boat-boat conformation may have less torsional strain (but more cross-ring interactions) than some of the other low-energy conformations of cyclooctane.

The nmr data presented here give considerable information on the symmetries of the favored conformations, and on the magnitudes of the barriers to interconversion of them. The conclusions which we can draw about the mechanisms of the interconversion processes are rather more conjectural. For example, in the earlier discussion of the twist-boat conformation perhaps more than reasonable stress was placed on the integrity of a series of interconversions involving passages through the itinerary twist-boat  $\rightleftharpoons$  boat-boat  $\rightleftharpoons$  twist-boat  $\rightleftharpoons$  boat  $\rightleftharpoons$  twist-boat  $\rightleftharpoons$  boat-boat  $\rightleftharpoons$  twist-boat, etc. As is reported in the Experimental Section, attempts to match theoretical and experimental spectra

(16) In the original work of Hendrickson<sup>3a</sup> and Wiberg<sup>3b</sup> on cyclooctane conformations the twist-boat configuration was not considered, but extension of the Wiberg procedure (unpublished results of D. L. Griffith) suggests that the twist-boat form is quite close to that of the boat-chair. The same conclusion has been recently published by Hendrickson<sup>3d</sup> (see Figure 1).

(17) J. M. Lehn and G. Ourisson, *Bull. Soc. Chim. France*, 1113 (1963), give a corrected formula for calculating dipolar interaction energies and the 2.99 kcal/mol is obtained by taking each CF<sub>2</sub> group to act as a point pole of 1.96 D located on the bisector of the F-C-F bond angle at the C-F bond distance, 1.36 Å from the carbon atom.

(18) Further evidence that CF<sub>2</sub> groups in conjunction with other polar groups can change conformational preferences has been provided by R. D. Stolow, T. W. Giants, and J. D. Roberts, *Tetrahedron Letters*, in press.

for the high-temperature process of perfluorocyclooctane were not satisfactory, even though the program used seemed to be applicable to the exchanges postulated for the inversion itinerary. One possible conclusion is that the complete conformational equilibration of the twist-boat or boat-boat forms of perfluorocyclooctane takes place not by way of the boat form, but by some other conformation outside the series, and this, of course, may also be true for 1,1,2,2-tetrafluorocyclooctane. The intermediate-temperature spectrum of the latter compound is rather symmetrical (Figure 6), so that coalescence of the several peaks to a singlet at high temperatures is not very sensitive to the model employed. One possible alternate path for inversion of these fluoro compounds is flipping of one carbon to take the twist-boat form over into the boat-chair series. After several pseudorotations, the boat-chair can return to a twist-boat form with the various substituent positions interchanged.

The magnitudes of the inversion and pseudorotation barriers found in this work deserve comment. The  $\Delta G^\ddagger$  for inversion of 1,1-difluorocyclooctane was found to be 7.5 kcal/mol, very close to that of cyclooctane itself, 8.1 kcal/mol.<sup>9</sup> These values are substantially lower than the 10.2-kcal/mol barrier for inversion of cyclohexane,<sup>6a</sup> and no doubt reflect the greater conformational mobility of the cyclooctane ring. Hendrickson<sup>3f</sup> has calculated relative energy maxima of 8.3 kcal/mol and 11.4 kcal/mol along the inversion paths for boat-chair and chair-chair conformations of cyclooctane, respectively. The  $\Delta G^\ddagger$  for inversion of 1,1,2,2-tetrafluorocyclooctane, 10.3 kcal/mol, is markedly higher than for the simple cases and this we have already suggested to be evidence for a difference in the favored conformation.

The values of  $\Delta G^\ddagger$  for pseudorotation of 1,1-difluorocyclooctane and 1,1,4,4-tetrafluorocyclooctane, 4.9 kcal/mol and 6.2 kcal/mol, respectively, indicate the general relative facility of pseudorotation compared to ring inversion. These  $\Delta G^\ddagger$  values for pseudorotation are close to those reported for the same process in cyclooctanone (6.3 kcal/mol) and cyclooctene (5.8 kcal/mol).<sup>19</sup> They are also close to the free energy of activation for the ring inversion of 1,1-difluoro-4,4-dimethylcycloheptane, 5.3 kcal/mol,<sup>20</sup> which is possibly in reality a pseudorotation process.<sup>7</sup>

The value for  $\Delta G^\ddagger$  for pseudorotation in 1,1,2,2-tetrafluorocyclooctane, 7.7 kcal/mol, again suggests that the conformation here is different and, because the barriers for this compound of both inversion and pseudorotation are higher than for the other cyclooctanes, it appears that, in general, the twist-boat conformation is rather rigid.

It should be noted that conclusions about conformations derived from nmr studies at very low temperatures need not apply at room temperature. The more symmetrical a conformation, the more negative its entropy, so that as one goes to higher temperatures, the free energy of symmetrical forms rises more rapidly than the free energy of unsymmetrical conformations. For this reason, there may be sufficient changes in the rela-

(19) M. St. Jacques, Ph.D. Thesis, University of California, Los Angeles, Calif., 1967.

(20) E. S. Glaser, Ph.D. Thesis, California Institute of Technology, Pasadena, Calif., 1965.

tive energies of the conformations to bring about substantial changes in the proportions of the conformations, at the upper end of the 200° temperature range covered in this research.

### Experimental Section

The nmr spectra were recorded with a Varian A56/60A and a HA-60 spectrometer operating at 56.4 MHz for fluorine and 60.0 MHz for protons, both instruments being equipped with probes suitable for low-temperature work. Decoupling was achieved with a Nuclear Magnetic Resonance Specialties Model SD-60 spin decoupler, monitored with a Hewlett-Packard Model 5245L counter. The sample temperatures were measured with a copper-constantan thermocouple inserted into the probe near the sample; this thermocouple was calibrated against a similar thermocouple inserted in a dummy sample to correct for differences between probe temperature and sample temperature.

**1,1-Difluorocyclooctane.** Phenylsulfur trifluoride<sup>21</sup> (16.6 g, 0.1 mol) was heated to 60° in a 100-ml three-necked, round-bottomed flask immersed in a water bath and equipped with a dropping funnel, reflux condenser, and a magnetic stirrer, and 10.0 g (0.08 mol) of cyclooctanone was added dropwise over 30 min. An exothermic reaction occurred, the water bath was removed, and the flask cooled in an ice bath when the temperature rose above 100°. After addition of the cyclooctanone was complete, the solution was heated in an oil bath at 100° for a further 30 min. The thick, dark reaction mixture was poured into ice water and extracted with pentane. The extracts were washed with dilute sodium bicarbonate solution and dried over magnesium sulfate. After removal of the solvent, distillation afforded 1 g (9%) of 1,1-difluorocyclooctane, bp 40–42° (33 mm). The infrared spectrum (CHCl<sub>3</sub>) showed characteristic carbon-fluorine bands in the 1000–1400-cm<sup>-1</sup> region. The pmr spectrum showed three broad bands at  $\delta$  1.0–2.0.

*Anal.* Calcd for C<sub>8</sub>H<sub>14</sub>F<sub>2</sub>: C, 64.83; H, 9.53; F, 25.63. Found: C, 64.99; H, 9.66; F, 25.55.

**1,1,4,4-Tetrafluorocyclooctane.** Cyclooctane-1,4-dione<sup>22</sup> (4.8 g, 0.034 mol) was treated with sulfur tetrafluoride (50.0 g, 0.42 mole) in the manner used for the preparation of 2,2-difluoro-*cis*-decalin<sup>23</sup> and yielded 2.25 g (36%) of the desired product with bp 65–70° (22 mm). The infrared spectrum (CHCl<sub>3</sub>) showed characteristic carbon-fluorine bands in the 1000–1400-cm<sup>-1</sup> region. The pmr spectrum gave a complex series of resonances between  $\delta$  1.5 and 2.0.

*Anal.* Calcd for C<sub>8</sub>H<sub>12</sub>F<sub>4</sub>: C, 52.13; H, 6.57; F, 41.26. Found: C, 51.82; H, 7.11; F, 40.81.

**1,1,2,2-Tetrafluorocyclooctane.** Cyclooctane-1,2-dione<sup>24</sup> (4.0 g, 0.0285 mol) was treated with 59.0 g (0.5 mol) of sulfur tetrafluoride by the same procedure as above and afforded 1.0 g (19%) of tetrafluoride, bp 150°. The infrared spectrum (CHCl<sub>3</sub>) of the compound showed characteristic strong absorptions in the 1050–1200-cm<sup>-1</sup> region. The pmr spectrum showed broad bands in the  $\delta$  1.5–2.5 region.

**Calculations.** The theoretical nmr spectra calculated as a function of exchange lifetimes,  $\tau$ , chemical shifts, couplings, and equilibrium constants for all of the compounds studied in this work except perfluorocyclooctane and the high-temperature exchange process of 1,1,2,2-tetrafluorocyclooctane were obtained with the aid of programs devised by Drs. J. L. Beauchamp, G. M. Whitesides, J. T. Gerig, and F. J. Weigert based on the equations of Alexander.<sup>26</sup>

Simulation of slow interconversion of twist-boat conformations through the boat-boat but not through the boat conformation was attempted with the program of Newmark and Sederholm<sup>27</sup> as modified by Dr. J. T. Gerig. With suitable choices of conformer populations and interconversion barriers, this program (originally devised for nmr studies of ethane rotamers<sup>27</sup>) is able to simulate the changes in spectra to be expected for conformational equilibration within the boat-boat series of conformations. For perfluorocyclooctane, the calculated spectra differ from the experimental spectra in that, as the rate increases from the low-temperature limit the central, broad peak (see Figure 7) merges with the sharp peak and these then merge with the downfield broad peak. However, it can be seen from Figure 7 that experimentally the two broad peaks merge first. These differences are sufficiently striking to suggest that the proposed equilibration path is not correct. The spectra for the high-temperature process in 1,1,2,2-tetrafluorocyclooctane calculated by the same method match the experimental spectra very well, but the spectra are on the whole so symmetrical, with five lines going to a broad peak and then to a sharp singlet (Figure 6), that it is difficult to be sure about the applicability of the model.

The estimated error in values of the free energies of activation is  $\pm 0.3$  kcal/mol, and in  $E_a$  values it is  $\pm 1.0$  kcal/mol. The values of the entropies of activation appear to be unrealistically high in most cases. This is likely to be the consequence of experimental difficulties in determining the rates at the temperatures involved. The estimated error in the entropies of activation is  $\pm 5$  eu and we do not believe it desirable to attach any great significance to the entropies.

**Acknowledgment.** We are much indebted to helpful suggestions in the course of this work from Professors F. A. L. Anet, Gerhard Binsch, and James B. Hendrickson.

(24) A. T. Blomquist and L. H. Liu, *ibid.*, **75**, 2153 (1953).

(25) D. E. Gwynn, unpublished results.

(26) S. Alexander, *J. Chem. Phys.*, **37**, 974 (1962).

(27) R. A. Newmark and C. H. Sederholm, *ibid.*, **43**, 602 (1965).

We are grateful to these authors for a listing of their program.

(21) *Org. Syn.*, **44**, 82 (1964).

(22) A. C. Cope, A. H. Keough, P. E. Peterson, H. E. Simmons, Jr., and G. W. Wood, *J. Am. Chem. Soc.*, **79**, 3900 (1957).

(23) J. T. Gerig and J. D. Roberts, *ibid.*, **88**, 2791 (1966).